

Control Ball Valve Type G

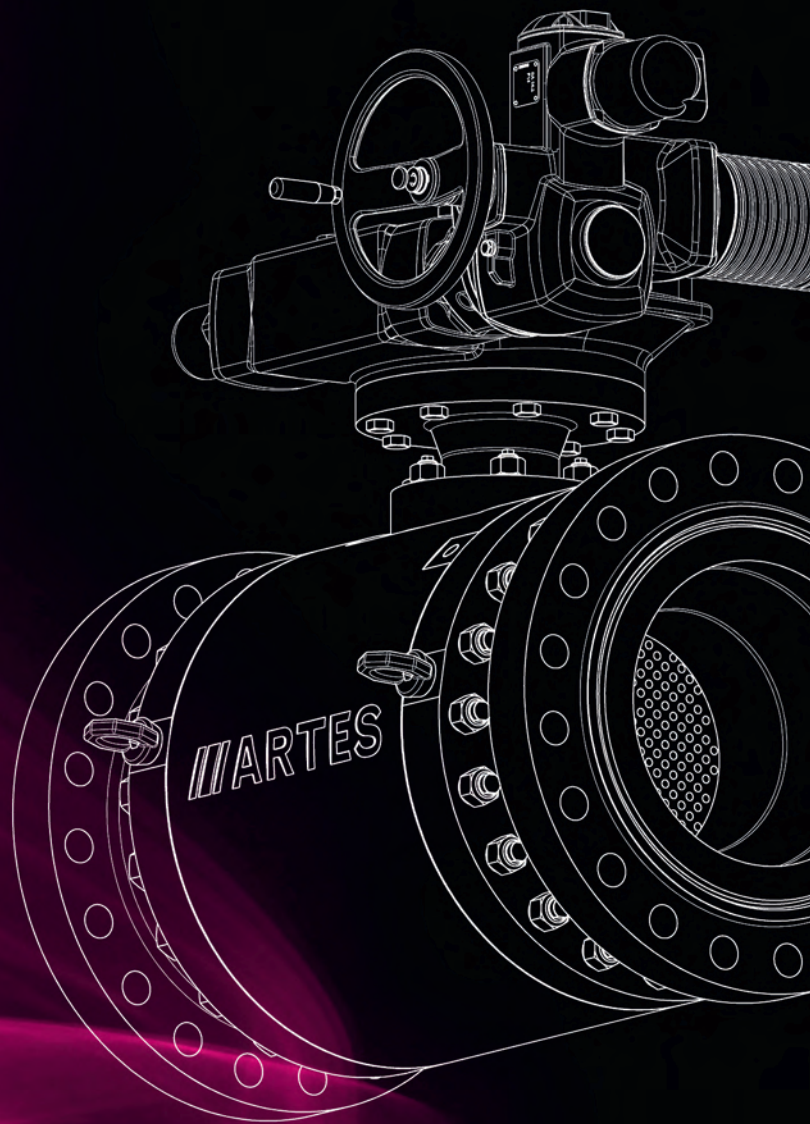

Purpose & Advantages

The ARTES control ball valve G is a control valve that has been specially designed for pressure and flow control. The design enables the secure shut off of the medium in addition to its control function. The valve is primarily for applications in the natural gas sector, the petrochemical industry, storage caverns and solution mining operations. Use in the transport of solids, such as ash transportation, is an additional area of application for this valve.



Typical places of use include:

- ▶ Compressor station for pressure and quantity regulation
- ▶ Transfer station to industrial consumers
- ▶ Burner control for industrial systems
- ▶ Storage (caverns, porous reservoirs):
Solution mining, storage, retrieval, cavern relief
- ▶ The valve is permanently leak-tight to the outside
- ▶ The straight flow-through of the valves enables a permanent pressure loss of 0.2 bar whilst guaranteeing constant control performance.
- ▶ Fast adaptation of the valve to changes in operational requirements by replacing the control discs
- ▶ Multi-stage pressure relief is possible
- ▶ The valve is highly resistant to wear due to its tungsten carbide coating
- ▶ Simple installation and removal, also for welded version

The design and the principle of rotary movement give the ARTES control ball valve G many crucial advantages:

- ▶ The purely metal seal of ball and seat ring ensures the seal in the ball passage



Cavern storage plant Etzel, Germany, IVG

Function

Control function

The ARTES control ball valve G performs two functions: Control and sealing. The two functions are separate from one another. The control function of an ARTES control ball valve G does not fundamentally differ from the control function of conventional control valves. Due to the 90° rotary movement of the ball, a defined portion of the control contour of the control disc is opened.

The process corresponds to the releasing of a control cross-section in the perforated cone of a globe valve. The type of control contour in the control disc determines the characteristic control curve of the valve. The control discs make it possible to reproduce any conceivable characteristic control curve with very high setting ranges of up to 1:200.

Compared to conventional control valves with a stroke movement, flow through the control ball valve is straight. This makes it possible to maintain a constant pressure loss of 0.2 bar whilst guaranteeing constant control performance.

For very high pressure differences between the inlet and outlet side of the valve, 2 controlled stages are available for pressure reduction. This makes it possible to achieve

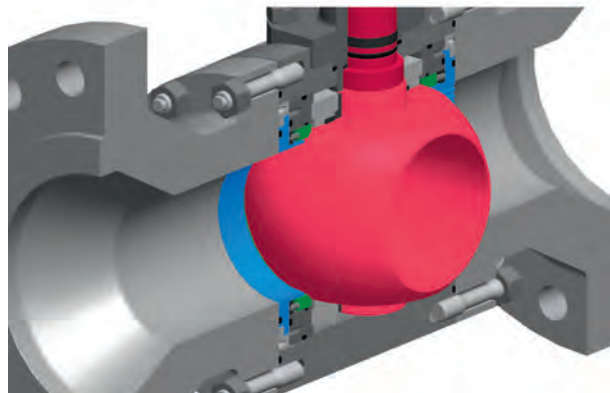

subcritical pressure reduction. Further-reaching requirements for a multi-stage pressure reduction can be achieved with additional fixed perforated discs. The ARTES control ball valve G is bi-directional and can thus be used as a supply or discharge control valve in natural gas storage or as a pressure control valve between different gas networks.

Seal function

Ball and seat ring perform the seal function. They are ground to match one another, making possible the purely metal seal of the gas-tight closure of the pipe. Ball and seat ring are coated with highly wear-resistant tungsten carbide.

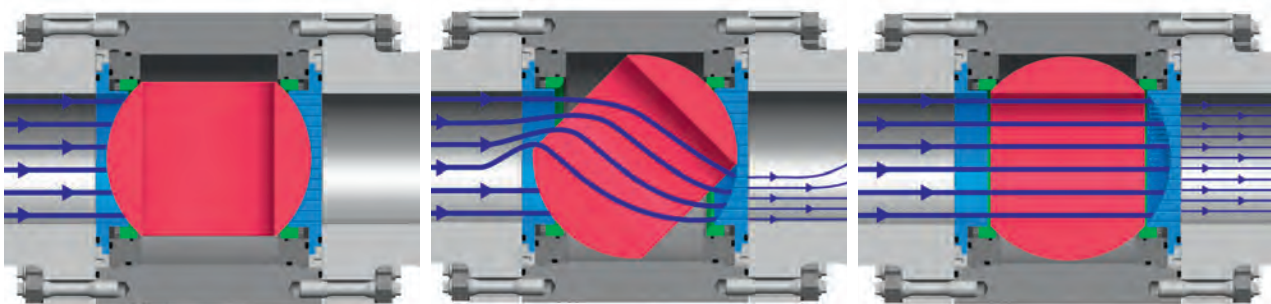

1. Closed control ball valve

2. Control ball valve 45° open

3. Control ball valve fully open

Design

The design of the ARTES control ball valve G makes it possible to adapt the Kv value and the control characteristics to changing operating parameters by replacing the control discs. This work can be performed on site.

The ARTES control ball valve G is available in 2-part or 3-part versions. The 2-part version has the advantage of shorter installation lengths..



3-part control ball valve



2-part control ball valve

Blow-out
proof stem

Adaptation to actuator
acc. to DIN/ISO 5211

Highly wear-resistant
seat ring, tungsten
carbide coated

Block & Bleed
testable

Design

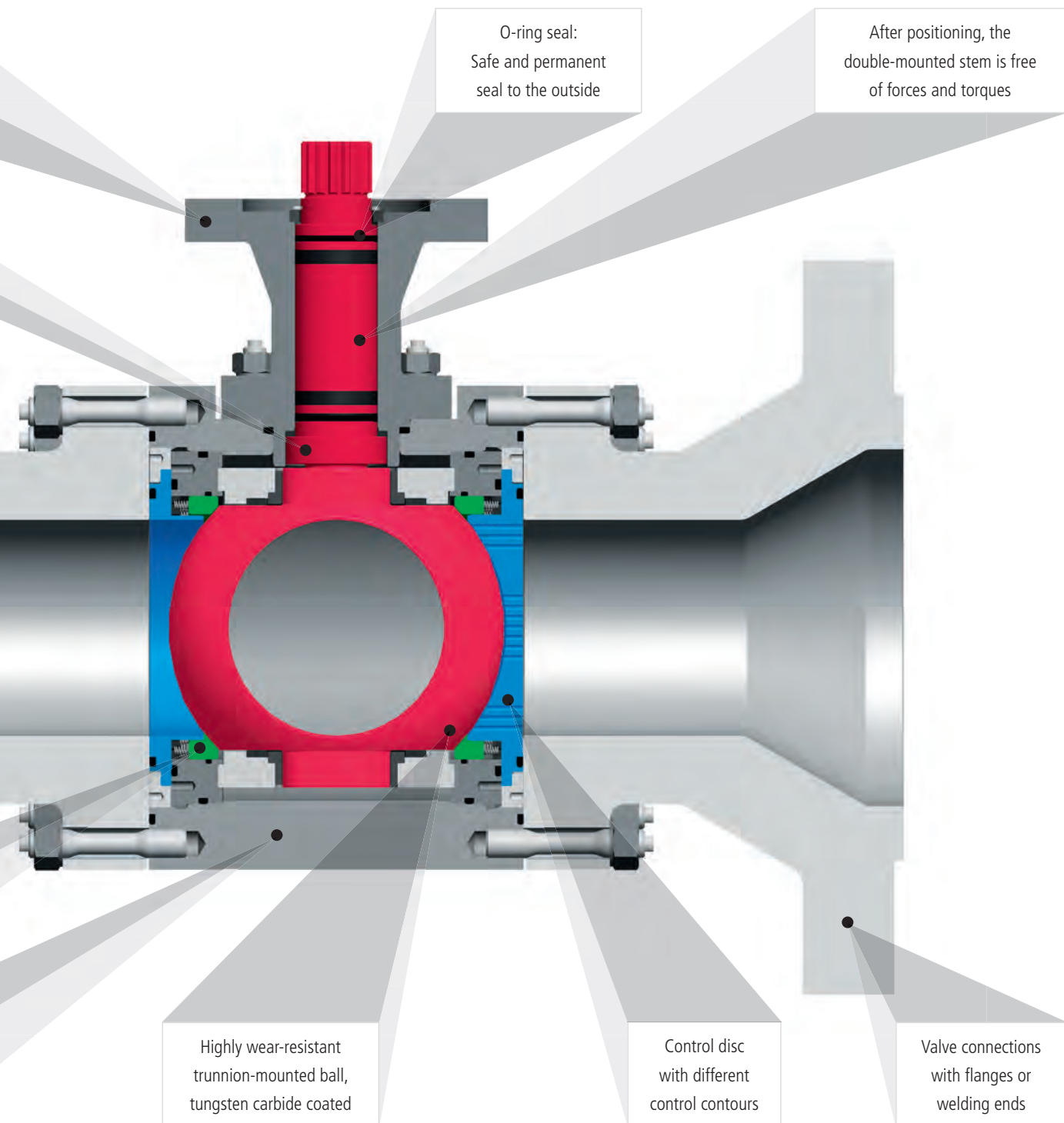

Versions / Applications

The valves shown here are representative of the diverse range of applications for the ARTES control ball valve G.



Type 25 with electric part-turn actuator
Connections: 1" 900 lbs
Location of use: Natural gas drying
Medium: Glycol



Type 500 with electric part-turn actuator
Connections: 24" 300 lbs
Location of use: Natural gas transport
Medium: Natural gas

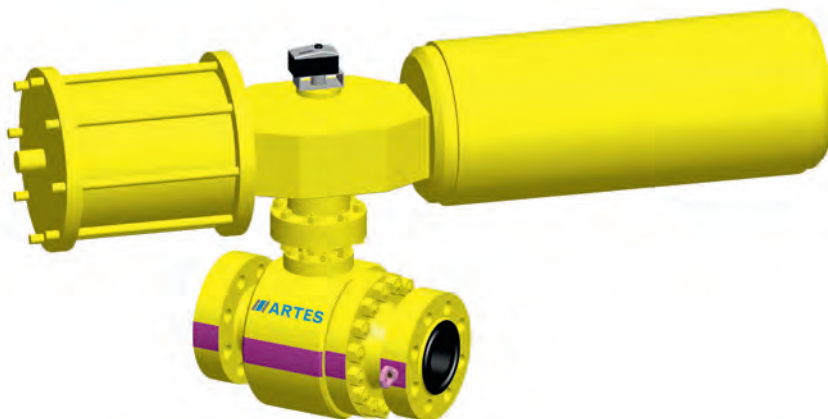

Type 150 with pneumatic part-turn actuator
Connections: 6" 2500 lbs
Location of use: Natural gas storage
Medium: Sour gas

Type 150 with electric part-turn actuator
Connections: 10" 600 lbs
Location of use: Cavern solution mining
Medium: Salt water



Facts

Nominal pipe size:	DN25 ... DN800 or 1" ... 32"
Nominal pressure class:	PN16 ... PN420 or ANSI class 300... 2500
Temperature:	- 80 ... 200 °C
Body material:	1.0460, 1.0566, 1.4541, 1.4571, 1.4462 or equivalent international materials
Seal material:	Viton®, FKM, FFKM, PTFE, EPDM, Chemraz® and others
Pipe connections:	flange (EN1092-1, ASME B16.5 and others), weld ends
Rangeability:	1:50 ... 200
Special versions:	Block & Bleed, Fire Safe Design
Media (examples):	Natural gas (sweet, sour) oil, salt water, water, glycol, synthetic gas

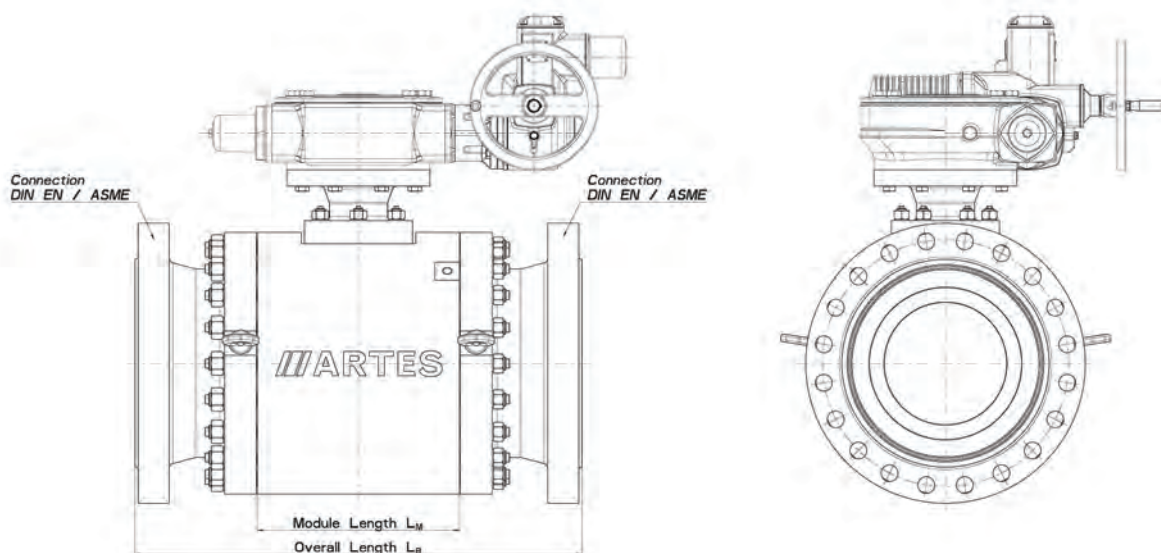

ARCA Flow Group



ARTES VALVE & SERVICE GmbH

www.artes-valve.de

- ▶ Control ball valves
- ▶ Desuperheater
- ▶ Motive steam coolers
- ▶ Steam conversion stations
- ▶ Differential pressure transmitters

Lessingstraße 79

D-13158 Berlin

Tel: +49 (0)30 91 20 47-10

Fax: +49 (0)30 91 20 47-20

E-Mail: info@artes-valve.de



ARCA-Regler GmbH

www.arca-valve.com

- ▶ Control valves
- ▶ Intelligent positioners
- ▶ Steam conversion valves
- ▶ Hygiene valves
- ▶ Pressure regulation units
- ▶ ECOTROL regulation valves



WEKA AG

www.weka-ag.ch

- ▶ Solenoid level indicators
- ▶ Tank content measuring systems
- ▶ Cryogenic components
- ▶ Inox valves



von Rohr Armaturen AG

www.von-rohr.ch

- ▶ Diaphragm valves
- ▶ Floor outlet valves
- ▶ Food-industry valves
- ▶ Sterile control valves
- ▶ Single-seat control valves
- ▶ Pneumatic lift actuators
- ▶ Corrosion-resistant control valves
- ▶ Electrical regulator actuators



Feluwa Pumpen GmbH

www.feluwa.com

- ▶ Hose diaphragm piston pumps
- ▶ MULTISAFE hose diaphragm piston pumps, for instance with metal diaphragm
- ▶ Sludge drainage facilities for mines
- ▶ Pump stations for pressure drainage
- ▶ Wastewater lifting facilities with cutter
- ▶ Separated sewage transfer facilities
- ▶ Homogenizing ducted-impeller pumps with cutter